

# LED Strip Light

*Installation Instructions*

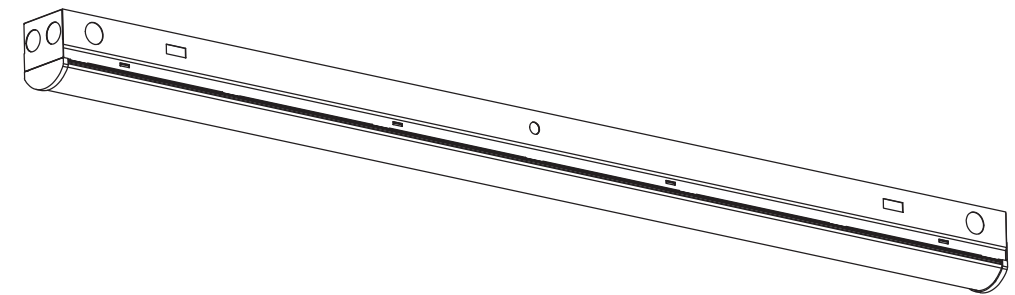

**ATTACH YOUR RECEIPT HERE**

Item Number \_\_\_\_\_ Purchase Date \_\_\_\_\_

Questions, problems, missing parts? Before returning to your retailer, call our customer service department at 1-866-492-6566.

**PACKAGE CONTENTS**

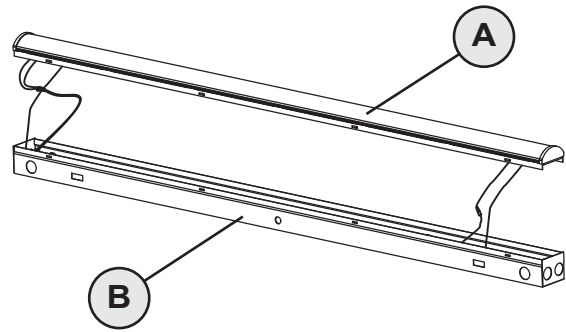

Part	Item Name	Qty.
A	LED cover assembly	1
B	Housing base	1

**HARDWARE CONTENTS**

AA

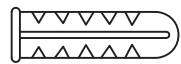

Drywall Anchor  
Qty. 2

BB



Wood Screw  
Qty. 2

CC



Wire Nut  
Qty. 5

**SAFETY INFORMATION**

Please read and understand this entire manual before attempting to assemble, operate or install the product. Failure to do so could lead to electric shock, fire or other injuries that could be hazardous or even fatal.

- Be sure the electricity to the wires you are working on is shut off. Either remove the fuse or turn off the circuit breaker.
- Changes or modifications not expressly approved by the party responsible for compliance could void the user's authority to operate the equipment.
- This product must be installed in accordance with local, state and national electrical codes.
- Installation work shall be completed by a licensed installer that is familiar with the construction and operations of the product.

**CAUTION:**

- This product is dimmable with 0-10v dimming systems only.
- Units configured with battery backup systems contain a rechargeable LiFePO4 type battery and must be recycled or disposed of properly according to local jurisdictions.

**NOTICE**

- This device complies with Part 15 of the FCC Rules. Operation is subject to the following two conditions: (1) This device may not cause harmful interference, and (2) this device must accept any interference received, including interference that may cause undesired operation.

**SAFETY INFORMATION**

**NOTICE:**

- This equipment has been tested and found to comply with the limits for a Class B digital device, pursuant to part 15 of the FCC Rules. These limits are designed to provide reasonable protection against harmful interference in a residential installation. This equipment generates, uses and can radiate radio frequency energy and, if not installed and used in accordance with the instructions, may cause harmful interference to radio or television reception, which can be determined by turning the equipment off and on. The user is encouraged to try to correct the interference by one or more of the following measures:
  - Reorient or relocate the receiving antenna.
  - Increase the separation between the equipment and the receiver.
  - Connect the equipment into an outlet on a circuit different from that to which the receiver is connected.
  - Consult the dealer or an experienced radio/TV technician for help.
- This Class B digital apparatus complies with Canadian ICES-003.

**INSTALLATION INSTRUCTIONS**

The below steps outline the surface mounting method, where fixture body is fastened directly to the mounting surface. Alternate mounting methods are outlined in the steps on

1. Gently press housing base (B) near one end of the fixture while pulling the metal part of the LED cover assembly (A) so that housing separates at the seam as shown.

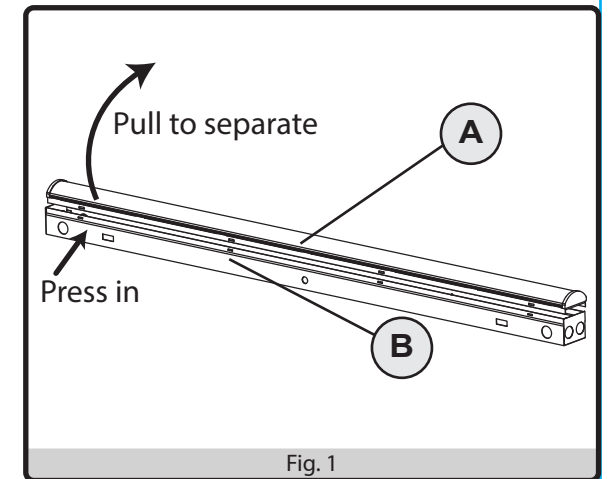

2. There is no need to disconnect the two halves of the fixture body. Support cables will support the weight of the LED cover assembly (A) during positioning of the housing base (B) up against the mounting surface.

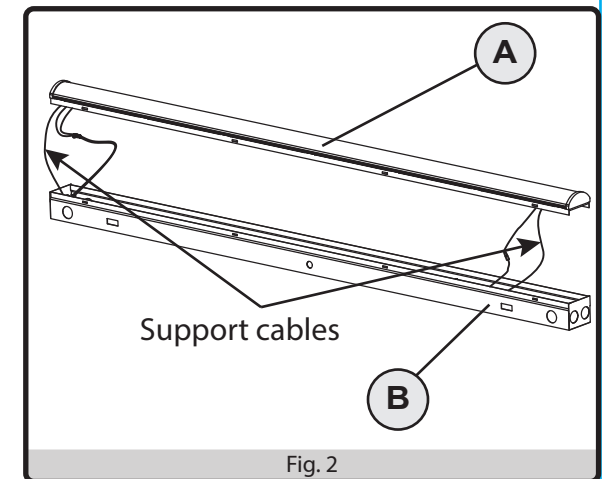

INSTALLATION INSTRUCTIONS

3. Align knockout hole with the supply wire location on junction box, adjust the fixture to the desired mounting angle and mark the mounting holes through the keyhole slots at both ends of the strip fixture housing base (B).

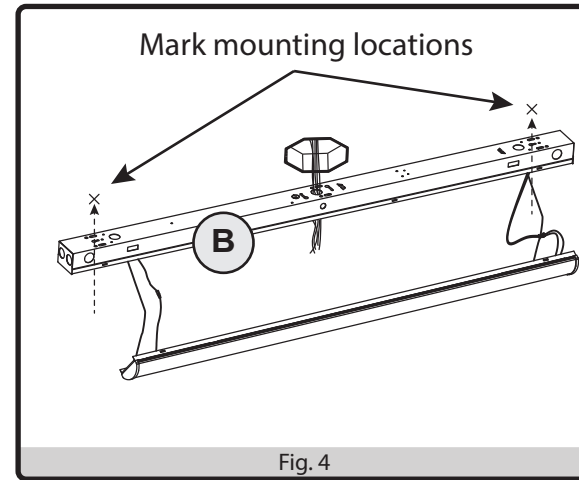

4. **DRYWALL MOUNTING:** If the mounting holes go through drywall without a stud, drill two small pilot holes using a 3/16-in. drill bit (not included), and install drywall anchors (AA) into the holes with a hammer (not included).

**CEILING STUD MOUNTING:** If the mounting holes go through ceiling studs, drill four small pilot holes using a 5/32-in. drill bit (not included) for the wood screws (BB).

**NOTE:** Install Wood screws (BB) but leave about 1/2-in. of space between the screw head and mounting surface.

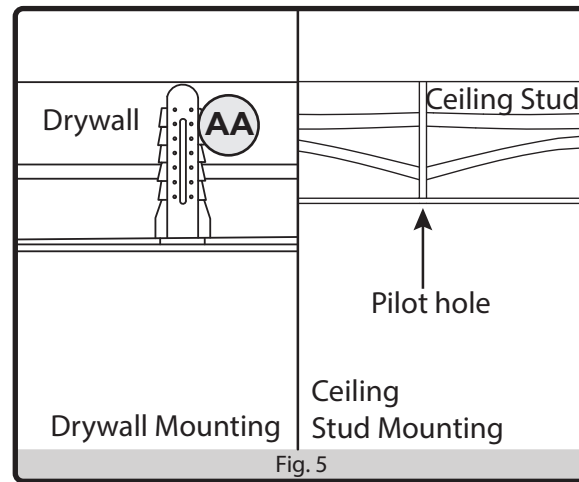

5. Feed the supply wires from the mounting surface through the knockout hole on the housing base (B). Guide the heads of the two wood screws into the keyhole slots and slide the housing base (B) in the direction such that the wood screw heads rest over the narrow part of the keyhole slot. Ensure that the fixture is supported and tighten the two wood screws (DD) until the fixture is secured to the mounting surface.

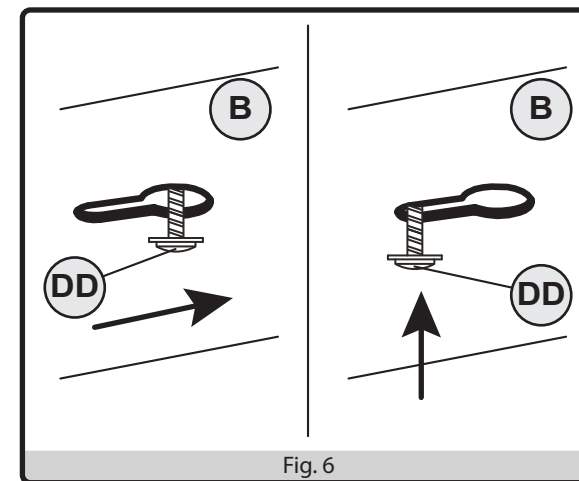

INSTALLATION INSTRUCTIONS

6a. If the fixture is equipped with an emergency battery backup system, proceed to step 6b, for fixtures without the battery backup system, proceed with 6a below: Connect the fixture wires to the supply wires -- black to black, white to white, and green to copper/bare. **WARNING:** If there is no ground supply wire, stop installation and consult a qualified electrician.

**NOTE:** If 0-10v dimming system is available, connect the purple and gray wires to the corresponding purple and gray wires in the building dimming system.

Once wire connections are made, secure each with a wire nut (CC).

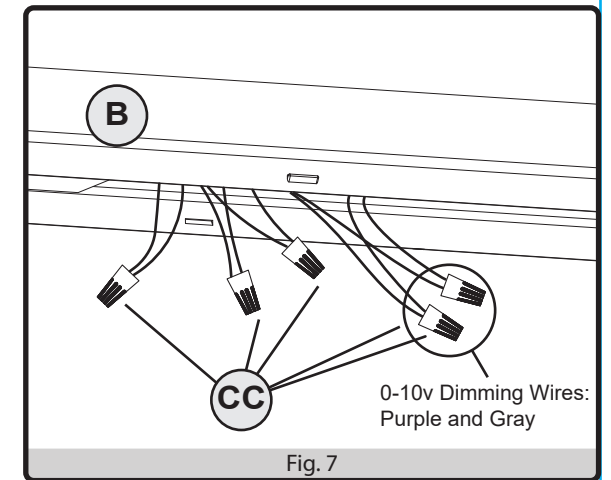

6b. **If the fixture is configured with an emergency battery back-up system:**

Connect neutral supply line to white, and ground supply line to green. Note that there are two line (hot) leads, labelled as "switched" and "unswitched", ensure that the "unswitched" lead is connected to constant building power (this lead senses the presence of a power outage); the "switched" lead is connected to the hot lead of a wall switch or control relay to turn fixture off without triggering the EM battery.

**NOTE:** Connect the two loose connector leads to enable the battery backup system.

If 0-10v dimming system is available, connect the purple and gray wires to the corresponding purple and gray wires in the building dimming system.

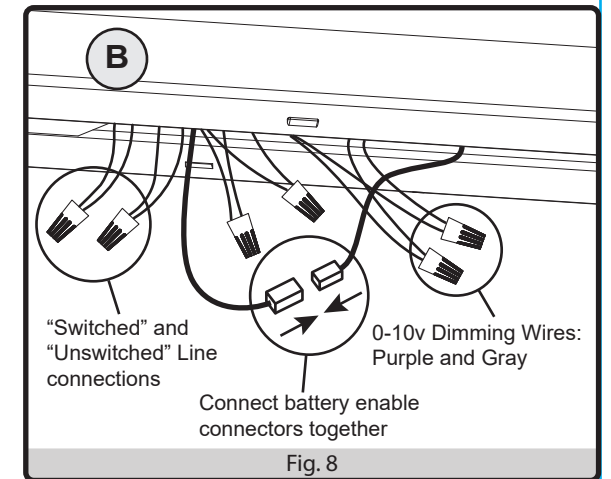

7. Tuck all loose wires and cables into the housing base (B). Gently press housing base (B) near one end of the fixture while securing the LED cover assembly (A) until all latches securely engage with the housing base (B).

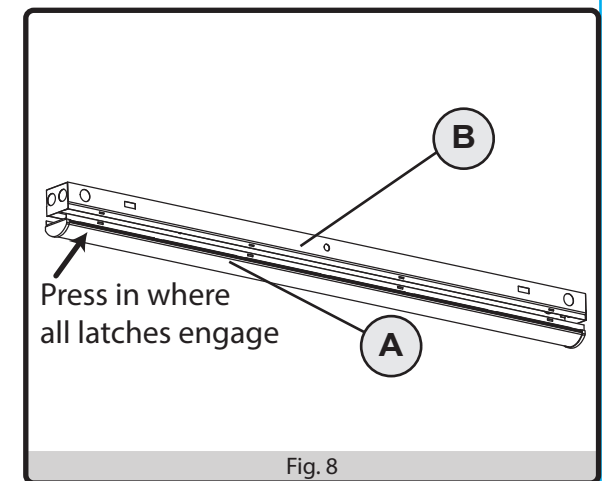

**INSTALLATION INSTRUCTIONS**

**Alternate Mounting Method A: Chain suspension**

A. Two slots on both ends of the fixture base (B) can be used to suspend the fixture using the optional hook and chain kit. Insert the "S" hook into the slots as shown, and suspend the other end of the chain to a secure hook location, or use the provided hooks after screwing into a wood mounting surface.

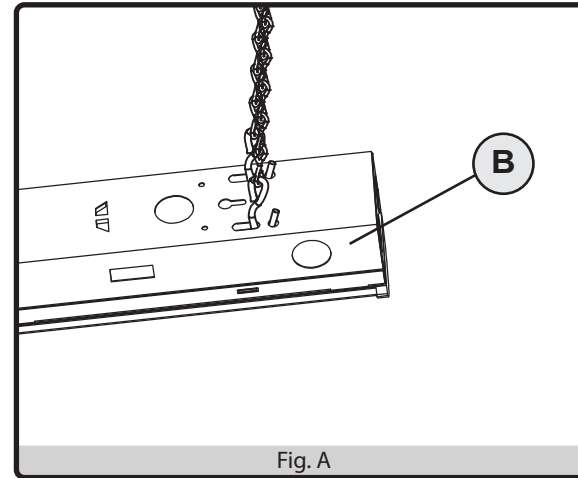

**Alternate Mounting Method B: Snap clips**

B. Align the junction box supply wires to the intended knockout location on the housing base (B), mark off the two locations where the mounting clips should be mounted to the surface to the respective catch locations. Secure the two mounting clips to the intended surface using the supplied wood screws and anchor (if necessary). Snap the fixture body to the mounting clips to secure the fixture and complete the wiring as needed in the prior steps above.

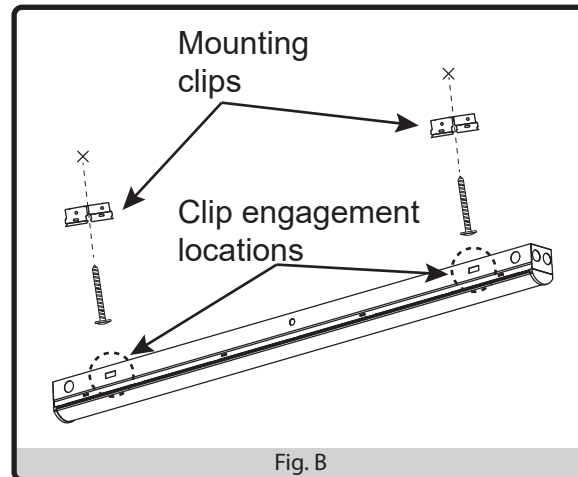

**Alternate Mounting Method C: Junction Box Cover Plate**

C. If the width of the fixture body fails to cover the junction box opening, a junction box cover plate can be used between the fixture and junction box. Mount the JBox cover plate (DD) over the junction box in the intended mounting surface, using the included screws. Ensure that all supply wires have been routed through the center opening.

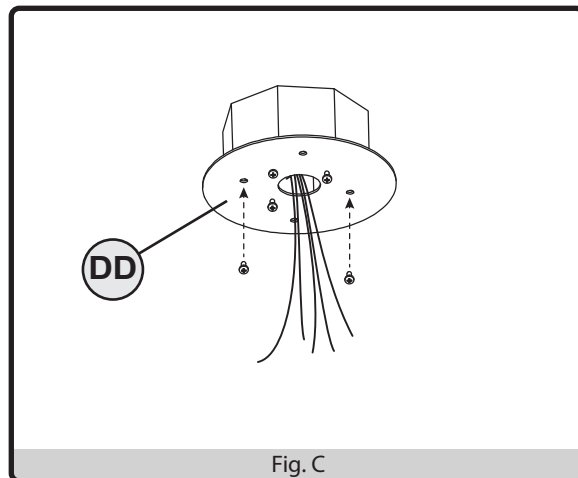

**CARE AND MAINTENANCE**

Clean with a mild, non-abrasive glass cleaner and soft cloth. Do NOT use solvents or cleaners containing abrasive agents. When cleaning the fixture, make sure the power is turned off, and any liquid spray should be applied to the cleaning cloth and not sprayed directly onto the fixture itself.

**TROUBLESHOOTING**

Problem	Possible Solution	Corrective Action
Fixture does not light.	1. Power is off. 2. Incorrect wire connection. 3. Defective wall switch.	1. Check circuit breaker or wall switch. 2. Check wire splices. 3. Replace switch.
Circuit breaker trips when light is turned on.	Crossed wires or power wire is grounded out.	Verify wires are correctly connected.

**WARRANTY**

This fixture is warranted to perform free from defects for five (5) years. If it fails to do so, you may return it with proof of purchase to 13445 12th St., Chino, CA 91710 for replacement.

# ZUV70A001 Remote

for Occupancy Sensor configuration



Energetic Lighting's ZUV70A001 remote will configure the occupancy sensors to operate at either a bi-level or tri-level state. Each operational stage can be configured to various light levels as well as desired time durations. Ambient light can also be factored in for daylight harvesting applications. Four custom memory slots are available to store specific configuration settings for instant upload of new settings.

## Features

- Bi-level or Tri-level modes
- Remote control configuration
- Integrated ambient daylight sensor
- Full auto-regulated lighting solution

## Applications

- Low-traffic locations
- Office rooms and walkways
- Unmanaged rooms
- General lighting

## Specifications

<b>Stand-by power:</b>	<0.5 W
<b>Detection range options:</b>	20%, 50%, 75%, 100%
<b>Persistent on-time duration (hold time):</b>	10sec, 1min, 5min, 10min, 15min, 20min, 30min, 60min
<b>Stand-by period (tri-level on duration):</b>	1min, 30min, 60min, ∞(bi-level mode)
<b>Stand-by period dimmed state levels:</b>	10%, 20%, 30%
<b>Ambient light harvest threshold:</b>	10 Lux, 30 Lux, 50 Lux, (disabled / always on), active sample
<b>Sensor Type:</b>	High frequency (microwave)
<b>Sensor Frequency:</b>	5.8 GHz (± 75 MHz)
<b>Maximum Detection Range:</b>	26-ft x 50-ft (lateral radius x height)
<b>Detection angle:</b>	30° - 150°
<b>Maximum Mounting Height:</b>	50-ft
<b>Operating Temperature:</b>	-40°F to 158°F

## Detection range profile plot

Please note that the detection profile is symmetrical vertically, and a full 360° overhead.

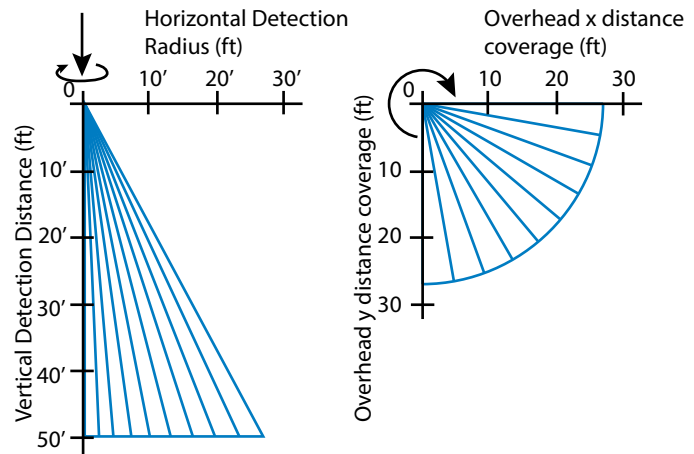

# ZUV70A001 Remote

## for Occupancy Sensor configuration

### Operation mode states

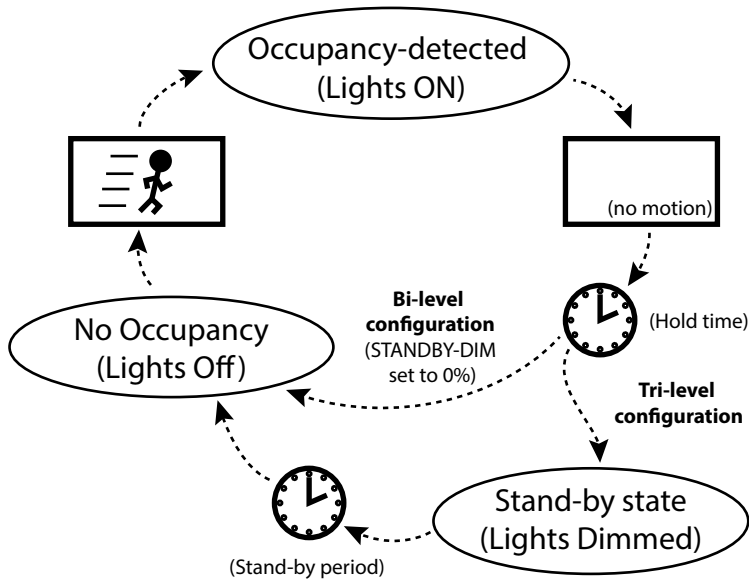

### Remote Controller Operation

**Brightness:** Sets the upper light level % during normal operation (occupancy), this is only set lower if lights are too bright, or to save even more power during normal operation.

**Sensitivity:** Sets the sensitivity of the motion sensor to vary the detection trigger. Reduce sensitivity value to reduce false triggers and filter out negligible motion.

**Hold-time:** Sets the time fixture is to remain in Occupancy-detected state (Lights on) after no motion has been detected.

**Stand-by period:** (Tri-level configuration) DIM: Sets the dimmed light % when no motion is detected, Select 0% for Bi-level configuration TIME: Sets the time duration to keep fixture in a dimmed Stand-by state after the no-motion hold time has expired.

**ON/OFF:** Manual override fixture to either full on, or full off without sensor.

**Display:** Displays setting indicator lights and ready to configure using direction arrow keys.

**Auto Mode:** Enables sensor control of fixture.

**Reset:** Restores factory default settings where motion sensor and daylight sensors are disabled.

**Test 2s:** This key is pressed to test the sensitivity of the motion detection setting, and will disable the stand-by settings and daylight sensor. After confirming motion sensor suitability, resume normal operation by pressing the AUTO key and exit the test mode.

**Transmission indicator LED:** Indicator LED will light up during data transmission to sensor module.

**Daylight Sensor:** Sets the minimum lux threshold needed to disable light activation. Ambient light above this threshold value will keep fixture in no-occupancy state (lowest level) regardless of motion detected by sensor. Pressing the button will sample the current lux level and set the minimum lux threshold to this level, or set to 10, 30, or 50 lux.

Select the button to disable daylight sensor (default). Daylight sensor upper threshold is enabled after pressing the key and choosing between 100, 300, or 500 lux.

**Send:** Uploads the current settings displayed on upper indicator lights, after desired configuration is completed.

**Arrow Keys:** Navigate and configure desired settings displayed on upper indicator lights. Press key to start with Brightness setting, current setting will be flashing. Use and to move up and down each setting row bank. Use and to toggle left and right through each setting within each row bank.

**Enable Daylight Sensor:** This key is used in conjunction with the Daylight Sensor settings bank shown above. Press this key after selecting the minimum threshold settings first to move the flashing cursor into the 100, 300, or 500 lux upper threshold bank.

**Preset modes:** These keys allow memory storage of up to 4 separate configurations. With all indicator lights off, press one of the Mode keys to display the current stored configuration. Use the arrow keys to make the desired settings through each category. Press center OK key to save configuration. To upload mode to sensor, press the mode key and then press the Send key to upload to settings.

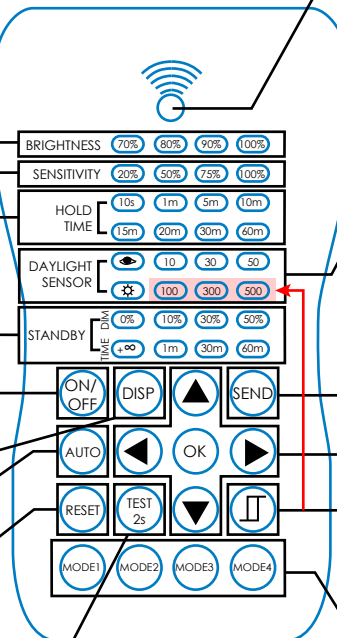

## Sample remote configurations

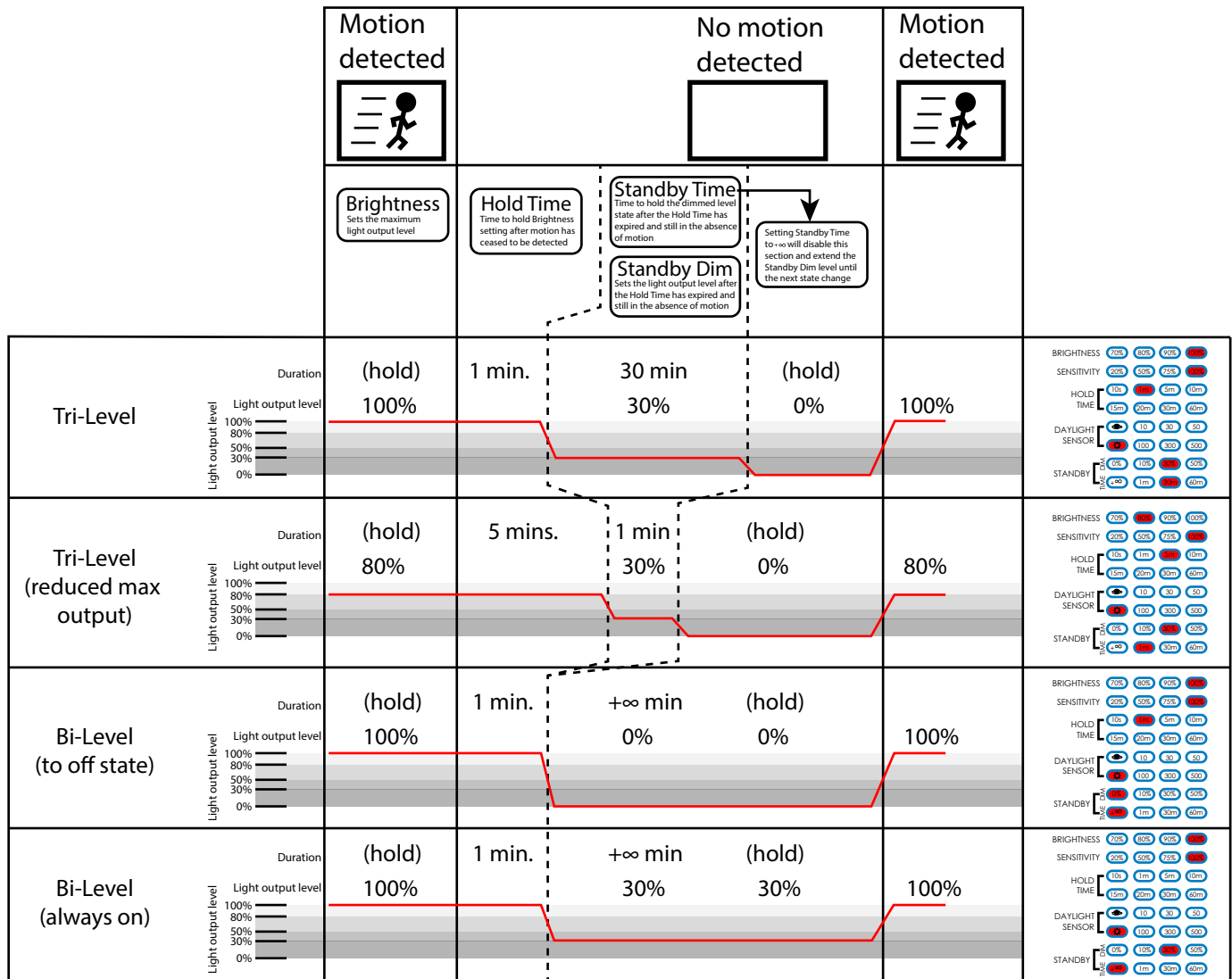

## Daylight / Ambient Light configuration

