

SCRT-320 Product Overview



SCRT-320 Petroleum Canopy LED Retrofit Kit – LSI Scottsdale* Retrofit

The Jarvis SCRT-320 is the industry's most advanced LED retrofit kit for the LSI Scottsdale* fixture. This retrofit kit is the only retrofit that replaces the existing fixture's entire optical unit while maintaining the existing fixture's mechanicals.



KEY FEATURES:

- Sealed optical unit replaces old glass lens.
- Existing fixture is left in place with no re-piping of conduit required.
- 14,000 lumens creates a bright, crisp appearance.
- 10 year warranty.
- Product is manufactured in the US of US and Imported Parts.

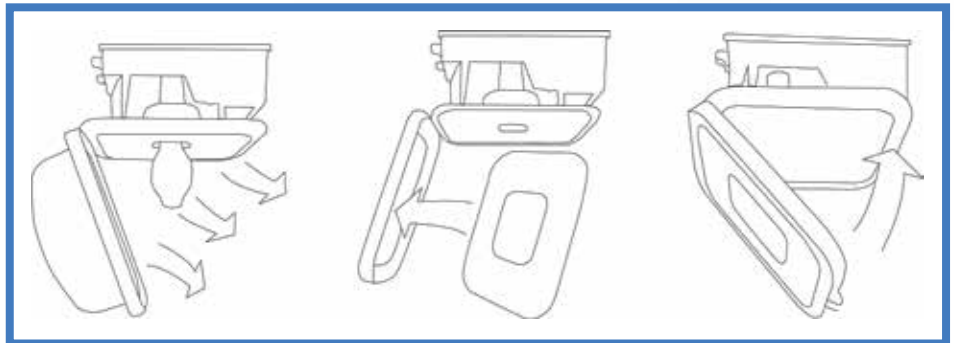

Most Popular Models and Specifications:

| Model | LEDs | INPUT | POWER | LUMENS | CCT | CRI | PF |
|----------|------|------------------|-------|-----------|-------|------|-------|
| SCRT-320 | 4 | 120-277V 50/60Hz | 107W | 14,680 lm | 5000K | ≥ 72 | ≥ 0.9 |

Full technical specifications available. Additional variants and models may be available. See "SCRT-320 Technical Spec Sheet" or contact a Jarvis representative for more information.



DDesignLights Consortium® (DLC) qualified product. Not all versions of this product may be DLC qualified. Please check the DLC Qualified Products List at www.designlights.org/QPL to confirm which versions are qualified.

ETL Classified to UL 1598C and UL 8750. Rated for wet locations.

*Scottsdale is a registered trademark of LSI Industries, Inc.